

This Question Paper contains 4 Printed Pages.

**19E(A)**

**GENERAL SCIENCE, Paper - I**

*(Physical Science)*

*(English version)*

**Parts A and B**

**Time : 2 hrs. 45 min]**

**[Maximum Marks : 40**

**Instructions :**

1. This paper contains **Part-A** and **Part-B**.
2. Answer the questions under **Part-A** on separate answer book. Write the answers to the questions under **Part-B** on the question paper itself and attach it to the answer book of **Part-A**
3. Answer **all** the questions. Internal choice is given to the questions under Section-III.
4. In the duration of 2.45 hours, 15 minutes of time is allotted to read the question paper.

**Part - A**

**Time : 2 hours**

**Marks : 30**

**Instructions :**

1. **Part-A** comprises **THREE** sections **I, II** and **III**.
2. **All** the questions are **compulsory**.
3. There is no over all choice. However, there is an internal choice to the questions under Section-III.

**SECTION - I**

- NOTE :** (i) Answer **all** the questions. 4×1=4  
(ii) Answer each question in 1 or 2 sentences.  
(iii) Each question carries **ONE** mark.

1. Iron gets rust but Gold doesn't, why ?

**19E(A)**

**V**

2. State Fermat's principle.
3. Can a virtual image be photographed by a camera ?
4. Give the names of the functional groups.
  - (a) - COOR
  - (b) - OH

### SECTION - II

**NOTE :** (i) Answer **all** the questions.

5×2=10

(ii) Answer each question in 4 or 5 sentences.

(iii) Each question carries **TWO** marks.

5. Your friend has a doubt that whether a concave mirror or a convex mirror is used as a rear - view mirror in the vehicles. What questions will you ask to clarify his doubts ?
6. The focal length of a converging lens is 20 cm. Where will the image be formed, if an object is placed at 60 cm from the lens ? Write characteristics of the image.
7. What is the reason for the blue colour of the sky ? How do you appreciate the role of molecules in the atmosphere in this regard ?
8. Name the principle, which says an Orbital can hold only 2 electrons, and explain.
9. How do you appreciate the special nature of Inert gases ?

**SECTION - III**

- NOTE :** (i) Answer **all** the questions. 4×4=16  
(ii) Answer each question in 8-10 sentences.  
(iii) There is internal choice for each question.  
(iv) Only one option from each question is to be attempted.  
(v) Each question carries **FOUR** marks.

**10.** Answer the following questions by using the data given in the table.

Substance	Specific Heat (Cal/g°C)
Lead	0.031
Aluminium	0.21
Copper	0.095
Water	1.00
Iron	0.115

- (a) Write SI units for Specific Heat.  
(b) Based on Specific Heat values, arrange the substances given in the table in ascending order.  
(c) If we supply same quantity of heat, which substance will heat up faster?  
(d) Calculate the amount of heat required to raise the temperature of 1 kg of Iron through 10°C.

**OR**

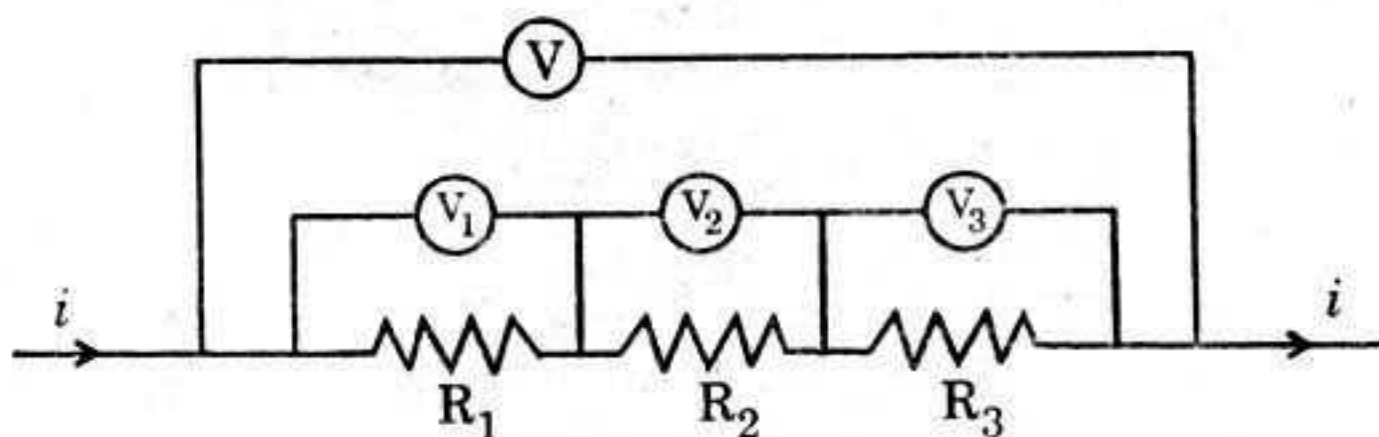

Observe the above diagram and answer the following.

- (a) Are all the resistors connected in parallel or series?  
(b) What is the equivalent resistance of the combination of three resistors?  
(c) In this system, which physical quantity is constant?  
(d) If  $R_1 = 2\Omega$ ,  $R_2 = 3\Omega$ ,  $R_3 = 4\Omega$ , find equivalent resistance.

[4]

11. Write the chemical formulae for Washing soda and Baking soda and give their uses.

**OR**

Who proposed Valence Bond Theory ? Explain the formation of  $N_2$  molecule by using this theory.

12. Explain the relation between angle of incidence and angle of refraction with an experiment.

**OR**

Write an activity to each of the following chemical reaction.

- (A) Photo-chemical reaction.  
(B) Chemical displacement reaction.
13. Name the device that converts electrical energy into mechanical energy. Draw its diagram and label the parts.

**OR**

What is a Furnace ? Draw Reverberatory furnace and label its parts.

---

This Question Paper contains 4 Printed Pages.

**19E(B)**

**GENERAL SCIENCE, Paper - I**

*(Physical Science)*

*(English version)*

**Parts A and B**

**Time : 2 hrs. 45 min.]**

**[Maximum Marks : 40**

**Instruction :** Write the answers to the questions in this **Part-B** on the Question paper itself and attach it to the answer book of **Part-A**.

---

**Part - B**

**Time : 30 min.**

**Marks : 10**

**SECTION - IV**

$20 \times \frac{1}{2} = 10$

**NOTE :**

1. Answer **all** the questions.
2. Each question carries  $\frac{1}{2}$  mark
3. Marks will **not** be awarded in any case of over-writing, rewritten or erased answers.
4. Write the **CAPITAL LETTER** (A, B, C, D) showing the correct answer for the following questions in the brackets provided against them.

14. The S.I. unit of Heat is ..... [     ]

(A) Calorie

(B) Joule

(C) Calorie /  $g^{\circ}C$

(D) Joule / Kg-kelvin

15.  $x \text{ KClO}_3 \rightarrow y \text{ KCl} + z \text{ O}_2$ . The respective values of x, y, z are ..... [     ]

(A) 1, 2, 3

(B) 3, 3, 2

(C) 2, 2, 3

(D) 2, 2, 2

**19E(B)**

**V**

16. The iron nail dipped in Copper sulphate solution becomes brown and the blue colour of the Copper sulphate solution fades.

Which type of reaction is this ?

[ ]

- (A) Chemical combination. (B) Chemical decomposition.  
(C) Double decomposition. (D) Displacement.

17. Find the values of  $\angle i$ ,  $\angle r$  in the diagram.

[ ]

(A)  $\angle i = 60^\circ$ ,  $\angle r = 60^\circ$

(B)  $\angle i = 60^\circ$ ,  $\angle r = 30^\circ$

(C)  $\angle i = 30^\circ$ ,  $\angle r = 60^\circ$

(D)  $\angle i = 30^\circ$ ,  $\angle r = 30^\circ$

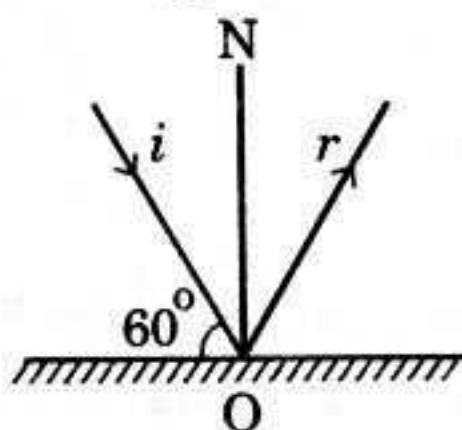

18. The colour of Methyl orange in alkali solutions is .....

[ ]

- (A) Yellow  
(B) Orange  
(C) Red  
(D) Blue

19. Which of the following is Snell's law ?

[ ]

(A)  $n_1 \sin i = \frac{n_2}{\sin r}$

(B)  $\frac{n_1}{n_2} = \frac{\sin i}{\sin r}$

(C)  $\frac{n_2}{n_1} = \frac{\sin i}{\sin r}$

(D)  $\frac{n_1}{\sin i} = n_2 \sin r$

20. Where should be the object placed on the principle axis of a Convex lens in order to get virtual image ?

[ ]

- (A) Between Optic centre and F. (B) At F.  
(C) Between F and C. (D) At C.

21. Statement P : Myopia can be corrected by using a bi-concave lens.

Statement Q : For a bi-concave lens,  $f$  value is positive.

[ ]

- (A) P is false, Q is true (B) P is true, Q is false.  
(C) Both P, Q are true. (D) Both P, Q are false.

[3]

22. The splitting of white light into 7 colours is called ..... [    ]  
(A) Scattering (B) Reflection  
(C) Refraction (D) Dispersion
23. Which rule is violated in the electronic configuration  $1s^2 2s^0 2p^2$ ? [    ]  
(A) Aufbau principle.  
(B) Hund's rule.  
(C) Pauli exclusion principle.  
(D) Octet rule.
24. If  $n = 2$ , then angular momentum quantum number  $l$  values = .... [    ]  
(A) 0, 1 (B) 0, 1, 2  
(C) 0 (D) 1, 2
25. On moving from top to bottom in a group,  
the values of Ionizational energy ..... [    ]  
(A) Increases. (B) Decreases.  
(C) No change. (D) Can't say.
26. The bond present in HCl molecule is ..... [    ]  
(A) Ionic bond. (B) Polar covalent bond.  
(C) Non-polar covalent bond. (D) None.
27. Shape of Ammonia molecule is ..... [    ]  
(A) Linear  
(B) Trigonal - Planar  
(C) Tetrahedron  
(D) Trigonal Pyramid
28. An unknown circuit draws a current of 2A from a 12V battery.  
Its equivalent resistance is ..... [    ]  
(A)  $24\Omega$  (B)  $6\Omega$   
(C)  $12\Omega$  (D)  $2\Omega$

29. The main difference between A.C. generator and D.C. generator is .....

[ ]

- (A) Carbon brushes
- (B) Magnets
- (C) Coil
- (D) Commutator

30. Observe the following table.

[ ]

<i>Metal</i>	<i>Ore</i>
P	Bauxite
Mercury	Q
R	Haematite

Identify the substances which are to be present in P, Q, R positions.

31. When Acetic acid reacts with Ethyl alcohol, we add conc.  $H_2SO_4$ .

This process is called .....

[ ]

- (A) Saponification.
- (B) Esterification.
- (C) Catenation
- (D) Isomerism

32. Graphite and Diamonds are two .....

[ ]

- (A) Isomers
- (B) Allotropes
- (C) Homologs
- (D) Metals

33. The name of  $CH_3-CH_2-CH_2-COOH$  is .....

[ ]

- (A) Propanoic acid
- (B) Propanaldehyde
- (C) Butanoic acid
- (D) Butanaldehyde