

CBSE Class 10 Science Most Repeated Questions: CBSE Class 10 Science exams often feature frequently repeated questions, making it essential for students to identify and focus on these topics during their preparation. Key areas such as the chapters on "Carbon and its Compounds," "Periodic Table," "Human Eye and Colourful World," and "Acids, Bases, and Salts" regularly appear in the exam.

CLASS 10TH SAMPLE PAPER

Additionally, questions related to formulas, definitions, and diagrams from chapters like "Life Processes" and "Magnetic Effects of Electric Current" are common. Practicing these repeated questions helps students improve their problem-solving skills and boosts their confidence in the exam, ensuring better performance.

CBSE Class 10 Science Most Repeated Questions

CBSE Class 10 Science is known for having certain questions that appear frequently in the exams. These CBSE Class 10 Science Most Repeated Questions often focus on important concepts like chemical reactions, laws of motion, electricity, and the human digestive system. Regular practice of these topics can greatly enhance students' chances of scoring well.

By analyzing previous years' question papers, students can identify patterns and prepare efficiently for the most likely questions that may appear in the upcoming exams. Below we have provided some of the questions -

CBSE Class 10 Science Question Paper 2024 will have

- **20 MCQs** of 1 mark each
- **6 Short Answer Type Questions-I** of 2 marks each
- **7 Short Answer Type Questions-II** of 3 marks each
- **3 Long Answer Type Questions** of 5 marks each

CBSE Class 10 Science 1 Mark Questions (MCQs)

1. The laws of reflection hold true for:

- (a) plane mirrors only
- (b) concave mirrors only
- (c) convex mirrors only

(d) all reflecting surfaces

2. When an object is kept within the focus of a concave mirror, an enlarged image is formed behind the mirror. This image is

- (a) real
- (b) inverted
- (c) virtual and inverted

(d) virtual and erect

3. A student plots V-I graphs for three samples of nichrome wire with resistances R_1 , R_2 and R_3 . Choose from the following statements that holds true for this graph.

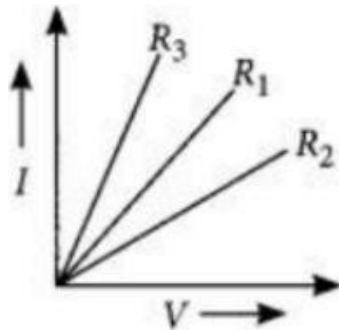

- (a) $R_1 = R_2 = R_3$
- (b) $R_1 > R_2 > R_3$
- (c) $R_3 > R_2 > R_1$
- (d) $R_2 > R_1 > R_3$**

4. Assertion (A) :The metals and alloys are good conductors of electricity.

Reason (R) : Bronze is an alloy of copper and tin and it is not a good conductor of electricity.

- (a) Both (A) and (R) are true and (R) is the correct explanation of the assertion (A).
- (b) Both (A) and (R) are true, but (R) is not the correct explanation of the assertion (A).
- (c) (A) is true, but (R) is false.**
- (d) (A) is false, but (R) is true.

5. Assertion (A) : Alloys are commonly used in electrical heating devices like electric iron and heater.

Reason (R): Resistivity of an alloy is generally higher than that of its constituent metals but the alloys have low melting points than their constituent metals.

(a) Both (A) and (R) are true and (R) is the correct explanation of the assertion (A).

(b) Both (A) and (R) are true, but (R) is not the correct explanation of the assertion (A).

(c) (A) is true, but (R) is false.

(d) (A) is false, but (R) is true.

6. The maximum resistance which can be made using four resistors each of $2\ \Omega$ is

(a) $2\ \Omega$

(b) $4\ \Omega$

(c) $8\ \Omega$

(d) $16\ \Omega$

7. Two bulbs of 100 W and 40 W are connected in series. The current through the 100 W bulb is 1 A. The current through the 40 W bulb will be

(a) 0.4 A

(b) 0.6 A

(c) 0.8 A

(d) 1A

CBSE Class 10 Science 2 Marks Questions

1. In electrolysis of water, why is the volume of gas collected over one electrode double that of gas collected over the other electrode?

2. Which of the following listed metals can displace zinc from its salt solution? Give reason for your answer with a chemical equation:

Copper, Lead, Magnesium, Silver

3. The reaction of metal X with Fe_2O_3 is highly exothermic and is used to join railway tracks. Identify metal X. Write the chemical equation for the reaction.

4. Write balanced chemical equation for the following reactions:
- Hydrogen sulphide burns in air to give water and sulphur dioxide.
 - Barium chloride reacts in aqueous solution with zinc sulphate to give zinc chloride and barium sulphate.
5. Differentiate between saprophytic nutrition and parasitic nutrition based on the type of food and manner of obtaining it.
6. What are the methods used by plants to get rid of excretory products?
7. Bile juice does not contain any enzyme but bile salts are important for digestion and absorption of fats. State reason.
8. What is a dominant trait with respect to height in pea plant. Give any two examples.
9. Trace the sequences of events through a reflex arc which occur when a bright light is focused on your eyes.
10. What is the magnification of the images formed by plane mirrors and why?
11. Draw a labelled ray diagram to show the path of the reflected ray corresponding to an incident ray of light parallel to the principal axis of a convex mirror. Mark the angle of incidence and angle of reflection on it.
12. An object is placed at a distance of 12 cm in front of a concave mirror of radius of curvature 30 cm. List four characteristics of the image formed by the mirror.

CBSE Class 10 Science 3 Marks Questions

1. State the property utilised in the following:

- Graphite in making electrodes.
- Electric wires are coated with polyvinyl chloride (PVC) or rubber like materials.
- Metal alloys are used for making bells and strings of music instruments.

2.a. An ore on treatment with dilute hydrochloric acid produces brisk effervescence. What kind of ore is this? What steps will be required to obtain metal from the enriched ore?

- Copper coin is kept immersed in silver nitrate solution for some time. What will happen to the coin and the colour of the solution? Write a balanced chemical equation for the reaction.

3. In the electrolysis of water:

- a. Name the gas collected at the cathode and anode respectively.
- b. Why is volume of gas collected at one electrode double than that at the other? Name this gas.
- c. How will you test this gas?

4. Differentiate between Photosynthesis and Respiration.

5. a. How is oxygen and carbon dioxide exchanged between blood and tissue? How are the gases transported in human being?

- b. What is haemoglobin?

6. Give schematic representation of different pathways of breakdown of glucose molecule.

7. What is the fate of glucose molecule in:

- a. Anaerobic respiration in Yeast and lactobacillus bacteria?
- b. Aerobic respiration in human cells.

Write chemical equation for each type.

8. What is DNA copying? State its importance.

9. Give reasons for the following:

- a. Traits acquired during lifetime of an individual are not inherited.
- b. All the human beings belong to a single species.
- c. Variations keep on accumulating during reproduction and do not disappear in next generation.

10. "It is a matter of chance whether a couple will have a male or a female child." Justify this statement by drawing a flow chart.

11. Name the type of mirrors used in the design of solar furnaces. Explain how high temperature is achieved by this device.

12. List two properties of the images formed by convex mirrors. Draw ray diagram in support of your answer.

13. The linear magnification produced by a spherical mirror is +3. Analyse this value and state the

- (i) type of mirror and

(ii) position of the object with respect to the pole of the mirror.

Draw a ray diagram to show the formation of image in this case.

15. The linear magnification produced by a spherical mirror is $+1/3$. Analysing this value state the

(i) type of mirror and

(ii) position of the object with respect to the pole of the mirror.

Draw any diagram to justify your answer.

16. Draw ray diagrams for the following cases when a ray of light:

(i) passing through centre of curvature of a concave mirror is incident on it.

(ii) parallel to principal axis is incident on convex mirror.

(iii) is passing through focus of a concave mirror incident on it.

17. Calculate the resistivity of the material of a wire of length 1 m, radius 0.01 cm and resistance 20 ohms.

18. Show how would you join three resistors, each of resistance $9\ \Omega$ so that the equivalent resistance of the combination is (i) $13.5\ \Omega$, (ii) $6\ \Omega$

19. Explain the use of an electric fuse. What type of material is used for fuse wire and why?

20. Two lamps, one rated 100 W; 220 V, and the other 60 W; 220 V, are connected in parallel to electric mains supply. Find the current drawn by two bulbs from the line, if the supply voltage is 220 V.

21. Name the hormones secreted by the following endocrine glands and specify one function of each:

(a) Thyroid

(b) Pituitary

(c) Pancreas

22. Give reasons:

a. Pituitary is often termed as master endocrine gland.

b. Pancreas helps in digestion and also regulates blood sugar level.

- c. Adrenals are known as glands of emergency.
23. Give the function(s) of the following plant hormones:
- a. Auxins
 - b. Gibberellins
 - c. Cytokinins
 - d. Abscisic acid
 - e. Ethylene

CBSE Class 10 Science 5 Marks Questions

1. Name a metal/non-metal

- a. Which makes iron hard and strong?
- b. Which is alloyed with other metal to make amalgam?
- c. Which is used to galvanise iron articles?
- d. Whose articles when exposed to air forms a black coating?

2. A metal (E) is stored under kerosene oil. When a small piece of it is left open in air, it catches fire. When the product formed is dissolved in water, it turns red litmus blue.

- a. Name the metal (E).
- b. Write the chemical equation for the reaction when it is exposed to air and when the product is dissolved in water.
- c. Explain the process by which metal is obtained from its molten chloride.

3. Give reason:

- a. Carbonate and sulphide ores are usually converted into oxides during the process of extraction of metals.
- b. Ionic compounds generally have high melting point.
- c. Hydrogen is not a metal but has been assigned a place in the reactivity series of metals.
- d. The galvanised iron article is protected against rusting even if the zinc layer is broken.

4.a.What are two vital functions of the human kidney?

b.Draw labelled diagram of human urinary system.

5.a.Define excretion.

b.Name the basic filtration unit present in the kidney.

c.Draw excretory system in human beings and label the following organs of excretory system which perform following functions:

(i) form urine

(ii) is a long tube which collects urine from kidney.

(iii) store urine until it is passed out.

6.The image of a candle flame placed at a distance of 30 cm from a mirror is formed on a screen placed in front of the mirror at a distance of 60 cm from its pole. What is the nature of the mirror? Find its focal length. If the height of the flame is 2.4 cm, find the height of its image. State whether the image formed is erect or inverted.

7.The image of an object formed by a mirror is real, inverted and is of magnification -1. If the image is at a distance of 40 cm from the mirror, where is the object placed? Where would the image be if the object is moved 20 cm towards the mirror? State reason and also draw ray diagram for the new position of the object to justify your answer.

8.It is desired to obtain an erect image of an object, using a concave mirror of focal length of 12 cm.

(i) What should be the range of distance of a , object placed in front of the mirror?

(ii) Will the image be smaller or larger than the object? Draw ray diagram to show the formation of image in this case.

(iii) Where will the image of this object be, if it is placed 24 cm in front of the mirror? Draw ray diagram for this situation also to justify your answer.

Show the positions of pole, principal focus and the centre of curvature in the above ray diagrams.

9.Define resistance of a conductor. State the factors on which resistance of a conductor depends. Name the device which is often used to change the resistance without changing the voltage source in an electric circuit. Calculate the resistance of 50 cm length of wire of cross sectional area 0.01 square mm and resistivity $5 \times 10^{-8} \Omega \text{ m}$.

10. Two wires A and B are of equal length and have equal resistances. If the resistivity of A is more than that of B, which wire is thicker and why? For the electric circuit given below calculate:

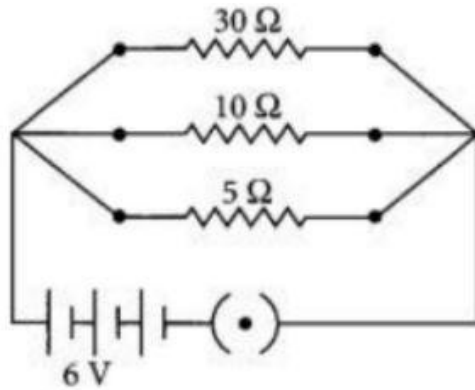

- (i) current in each resistor
- (ii) total current drawn from the battery, and
- (iii) equivalent resistance of the circuit.

11. An electric lamp of resistance $20\ \Omega$ and a conductor of resistance $4\ \Omega$ are connected to a $6\ \text{V}$ battery as shown in the circuit. Calculate.

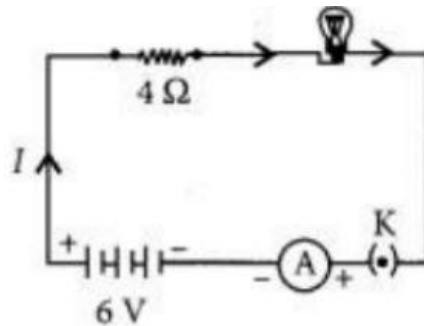

- (a) the total resistance of the circuit
- (b) the current through the circuit,
- (c) the potential difference across the (i) electric lamp and (ii) conductor, and
- (d) power of the lamp

Benefits of Practicing CBSE Class 10 Science Most Repeated Questions

Practicing the most repeated questions from CBSE Class 10 Science has several benefits for students:

1. Familiarity with Exam Pattern:

By regularly practicing the most repeated questions, students become familiar with the type and format of questions that frequently appear in the exam. This helps in understanding the exam pattern, including the weighting of different chapters.

2. Improved Time Management:

Regular practice of repeated questions enables students to gauge how much time they need to answer each type of question. This helps in developing effective time management skills during the actual exam.

3. Better Retention and Understanding:

Revisiting important questions reinforces key concepts and improves retention. Since these questions are often linked to core topics, practicing them ensures a deeper understanding of the subject matter, which can lead to higher marks.

4. Enhanced Problem-Solving Skills:

Repeated practice enhances problem-solving abilities, particularly in complex sections like Physics and Chemistry, where application of concepts is critical. It builds confidence in handling tricky and concept-heavy problems.

5. Boosted Confidence:

Practicing well-known questions gives students a sense of accomplishment, building their confidence before the exam. They become more comfortable with their preparation and reduce exam-related anxiety.

6. Identification of Weak Areas:

By practicing these questions, students can identify areas where they might be lacking or struggling. This allows for focused revision and ensures that weak topics are addressed before the exam.