

Class X Session 2024-25
Subject - Science
Sample Question Paper - 10

Time Allowed: 3 hours

Maximum Marks: 80

General Instructions:

1. This question paper consists of 39 questions in 5 sections.
2. All questions are compulsory. However, an internal choice is provided in some questions. A student is expected to attempt only one of these questions.
3. Section A consists of 20 objective-type questions carrying 1 mark each.
4. Section B consists of 6 Very Short questions carrying 02 marks each. Answers to these questions should be in the range of 30 to 50 words.
5. Section C consists of 7 Short Answer type questions carrying 03 marks each. Answers to these questions should be in the range of 50 to 80 words.
6. Section D consists of 3 Long Answer type questions carrying 05 marks each. Answers to these questions should be in the range of 80 to 120 words.
7. Section E consists of 3 source-based/case-based units of assessment of 04 marks each with sub-parts.

Section A

1. The copper articles turn green when kept for long due to [1]



- a) Corrosion b) Rusting
- c) Precipitation d) Rancidity
2. When iron filings are added to a solution of CuSO_4 , the reaction taking place is a- [1]
- a) Redox reaction b) Combination reaction
- c) Displacement reaction d) Decomposition reaction
3. Which of the following salts contains water of crystallization? [1]
- A. Gypsum
- B. Epsom salt
- C. Blue vitriol
- D. Glauber's salt

a) C and D

b) A, B, C and D

c) A and B

d) B and D

4. When ethanol reacts with sodium two products are formed. These products are: [1]

a) Sodium ethanoate and oxygen

b) Sodium ethoxide and oxygen

c) Sodium ethoxide and hydrogen

d) Sodium ethanoate and hydrogen

5. Aluminum is used for making cooking utensils. Which of the following properties of aluminum are responsible for the same? [1]



i. Good thermal conductivity

ii. Good electrical conductivity

iii. Ductility

iv. High melting point

a) (i) and (ii)

b) (i) and (iii)

c) (ii) and (iii)

d) (i) and (iv)

6. Which one of the following statements is true about the position of metals in the activity series of metals? [1]

a) Copper is below hydrogen but above lead

b) Iron is below lead and zinc

c) Zinc is below magnesium but above aluminium

d) Magnesium is below calcium but above aluminium

7. Ethane - with the molecular formula C_2H_6 has [1]

a) 9 covalent bonds

b) 8 covalent bonds

c) 7 covalent bonds

d) 6 covalent bonds

8. If the solute concentration of raisin is more inside then: [1]

a) endosmosis rate will be same

b) endosmosis rate will be less

c) endosmosis rate will be more

d) endosmosis process will not occur

9. Select the group which shares maximum number of common characters- [1]

a) two genera of a family

b) two individuals of a species

c) two species of a genus

d) two genera of two families

10. In human beings, fertilization of ovum takes place in: [1]

a) Fallopian tubes

b) Ovary

c) Uterus

d) Vagina

11. The component of a chromosome that controls heredity is [1]

- a) Histones
c) RNA
- b) Proteins
d) DNA
12. The blood leaving the tissues becomes richer in [1]
a) Oxygen
b) Hemoglobin
c) Water
d) Carbon dioxide
13. The strength of an electromagnet after the limit cannot be increased by increasing the current through the solenoid. What is the reason behind this phenomenon? [1]
a) Voltage through the solenoid gradually starts to decrease.
b) Electrons start to corrode the solenoid.
c) Resistance of the solenoid increases.
d) Current flowing through the solenoid is saturated.
14. Two LED bulbs of 12W and 6W are connected in series. If the current through 12W bulb is 0.06A the current through 6W bulb will be: [1]
a) 0.12A
b) 0.04A
c) 0.08A
d) 0.06A
15. Food chains generally do not exceed above 3 or 4 trophic levels because _____. [1]
a) A producer cannot be eaten by more than two herbivores
b) Transfer of energy from one trophic level to other is associated with energy loss
c) There are limited number of organisms in an ecosystem
d) Larger food chains increase complications of food web
16. Food web is constituted by [1]
a) relationship between animals and environment.
b) relationship between plants and animals
c) various interlinked food chains in an ecosystem
d) relationship between the organisms and the environment
17. **Assertion (A):** Silver articles become black after sometime when exposed to sunlight. [1]
Reason (R): It is because silver reacts with carbonates present in the air.
a) Both A and R are true and R is the correct explanation of A.
b) Both A and R are true but R is not the correct explanation of A.
c) A is true but R is false.
d) A is false but R is true.
18. **Assertion (A):** DNA copying is necessary during reproduction. [1]
Reason (R): DNA copying leads to the transmission of characters from parents to offspring.
a) Both A and R are true and R is the correct explanation of A.
b) Both A and R are true but R is not the correct explanation of A.
c) A is true but R is false.
d) A is false but R is true.
19. **Assertion (A):** A compass is kept near a wire carrying current gets deflected. [1]
Reason (R): Electric current is capable of producing a magnetic effect.

- a) Both A and R are true and R is the correct explanation of A. b) Both A and R are true but R is not the correct explanation of A.
- c) A is true but R is false. d) A is false but R is true.

20. **Assertion (A):** Recycling is the way of managing plastic waste. [1]

Reason (R): Broken plastic articles are sent to plastic processing units where they are melted and remoulded to make new plastic articles.

- a) Both A and R are true and R is the correct explanation of A. b) Both A and R are true but R is not the correct explanation of A.
- c) A is true but R is false. d) A is false but R is true.

Section B

21. Intake of small quantity of methanol can be lethal. Comment. [2]

22. i. Write the names of those parts of a flower which serve the same functions as the following do in the animals. [2]

- a. Testis
b. Sperm
c. Ovary
d. Egg

ii. State the function of flowers in the flowering plants?

23. a. Why is it important to prevent oxygenated and deoxygenated blood from mixing in birds and mammals? [2]

b. Which animals can tolerate some mixing of the oxygenated and deoxygenated blood streams? On what factor does the body temperature of these animals depend?

OR

Differentiate between Respiration and Photosynthesis.

24. Draw a ray diagram showing the path of rays of light when it enters with oblique incidence [2]

- i. from air into water,
ii. from water into air.

25. Your uncle has come from the village to renew the contract to supply frogs to the laboratories of the colleges of the town. While talking to you, he mentioned that cases of malaria have increased in his village. In addition population of grasshoppers has also increased who are damaging crops. [2]

- i. What could be the reasons for such problems faced by villagers?
ii. What suggestions will you give to your uncle?

OR

In the given figure, the various trophic levels are shown in a pyramid. At which trophic level is maximum energy available?

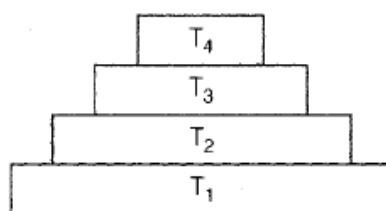

26. When a beam of white light is passed through a triangular glass prism, it gets dispersed into its seven colour components. Why do we get these colours? In the given figure, the colours X and Y represent the extreme [2]

components of the spectrum. Identify X and Y.

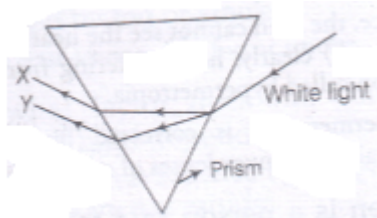

Section C

27. 'M' is an element which may be one out of Cu, Fe, Al, Na. It shows the following properties: [3]
- One of its ore is rich in M_2O_3 .
 - M_2O_3 is not affected by water.
 - It corrodes easily.
 - It forms chlorides MCl_2 and MCl_3 . Identify 'M'.

28. i. By the transfer of electrons, illustrate the formation of bond in magnesium chloride and identify the ions present in this compound. [3]
- ii. Ionic compounds are solids. Give reasons.
- iii. With the help of a labelled diagram show the experimental set up of action of steam on a metal.

OR

- i. Distinguish between ionic and covalent compounds under the following properties:
- Strength of forces between constituent elements
 - Solubility of compounds in water
 - Electrical conduction in substances
- ii. Explain how the following metals are obtained from their compounds by the reduction process:
- Metal M which is in the middle of the reactivity series.
 - Metal N which is high up in the reactivity series. Give one example of each type.
29. Explain how deoxygenated blood travels from body to lung for purification. Draw well-labelled diagram in support of your answer. [3]
30. Two plants, A with white flowers and B with red flowers were crossed. The F_1 progeny shows all red flowers and F_2 has three red and one white. Categorise the trait as dominant and recessive. [3]
31. Differentiate between virtual image formed by a concave mirror and of a convex mirror. [3]
32. Derive the relation between kilowatt hour and joule. [3]
33. i. A wire of resistance 2 has been connected to a source of 50 V as its two ends. What is the current flowing through the wire? [3]
- ii. An electric kettle rated at 220 V, 2.2 kW works for 3h. Calculate the energy consumed and the current drawn.

Section D

34. i. What are soaps? Explain the mechanism of cleansing action of soap with the help of a labelled diagram. [5]
- ii. Detergents are better than soaps. Justify.

OR

- Define the term **isomer**.
- Two compounds have same molecular formula C_3H_6O . Write the name of these compounds and their structural formula.
- How would you bring the following conversions:

- i. Ethanol to ethene
- ii. Propanol to propanoic acid

35. Explain the term fission as used in relation to reproduction. [5]

OR

How phototropism does occur in plants?

36. An object 4.0 cm in size, is placed 25.0 cm in front of a concave mirror of focal length 15.0 cm. [5]

- i. At what distance from the mirror should a screen be placed in order to obtain a sharp image?
- ii. Find the size of the image.

iii. Draw a ray diagram to show the formation of image in this case.

OR

- i. One half of a convex lens of focal length 10 cm is covered with a black paper. Can such a lens produce an image of a complete object placed at a distance of 30 cm from the lens? Draw a ray diagram to justify your answer.
- ii. A 4 cm tall object is placed perpendicular to principal axis of a convex lens of focal length 20 cm. The distance of the object from the lens is 15 cm. Find the nature, position and the size of the image.

Section E

37. Read the text carefully and answer the questions: [4]

Copper sulphate crystal contains water of crystallisation when the crystal is heated the water is removed and salt turns white. The crystal can be moistened again with water. The water of crystallisation is the fixed number of water molecules present in 1 formula unit of copper sulphate. On heating gypsum at 373K, it loses water molecules and became calcium sulphate hemihydrate.

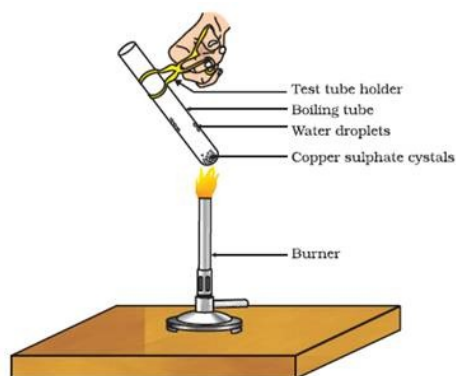

- (a) If the crystal is moistened with water, then which colour of the crystal reappears?
- (b) What is the commercial name of calcium sulphate hemihydrate?

OR

How many water molecules are present in one formula unit of copper sulphate?

38. Read the text carefully and answer the questions: [4]

Environmental triggers such as light, or gravity will change the directions that plant parts grow in. These directional, or tropic, movements can be either towards the stimulus or away from it. So, in two different kinds of phototropic movement, shoots respond by bending towards light while roots respond by bending away from it. How does this help the plant? Plants show tropism in response to other stimuli as well. The roots of a plant always grow downwards while the shoots usually grow upwards and away from the earth. This upward and downward growth of shoots and roots, respectively, in response to the pull of earth or gravity, is, obviously, geotropism. If 'hydro' means water and 'chemo' refers to chemicals, what would 'hydrotropism' and 'chemotropism' mean? Can we think of examples of these kinds of directional growth movements? One example of chemotropism is the growth of pollen tubes towards ovules, about which we will learn more when

we examine the reproductive processes of living organisms.

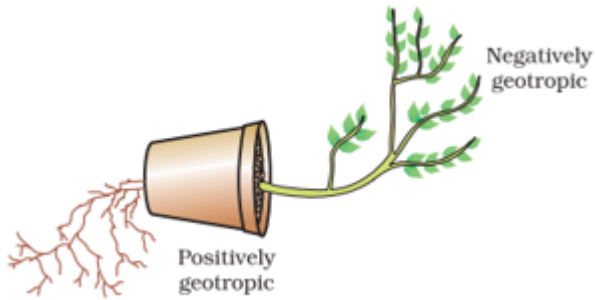

- (a) Where does negative phototropism occur in plants?
- (b) Phototropism in shoots is attributed due to which plant hormone?
- (c) Tendrils exhibit/ twining of tendrils show which type of tropic movement?

OR

If the stem grows towards sunlight and the root grows just opposite to it, then what type of movement of the stem is it?

39. **Read the text carefully and answer the questions:**

[4]

A student was asked to perform an experiment to study the force on a current carrying conductor in a magnetic field. He took a small aluminum rod AB, a strong horse shoe magnet, some connecting wires, a battery and a switch and connected them as shown. He observed that on passing current, the rod gets displaced. On reversing the direction of current, the direction of displacement also gets reversed. On the basis of your understanding of this phenomenon, answer the following questions :

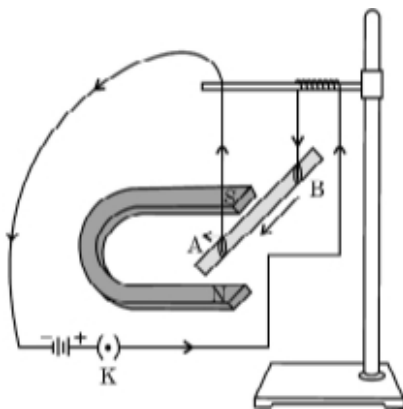

- (a) State the condition under which the displacement of the rod is largest for the same magnitude of current flowing through it.
- (b) State the rule that determines the direction of the force on the conductor AB.
- (c)
 - i. If the U shaped magnet is held vertically and the aluminum rod is suspended horizontally with its end B towards due north, then on passing current through the rod from B to A as shown, in which direction will the rod be displaced?
 - ii. Name any two devices that use current carrying conductors and magnetic field.

OR

Draw the pattern of magnetic field lines produced around a current-carrying straight conductor held vertically on horizontal cardboard. Indicate the direction of the field lines as well as the direction of the current flowing through the conductor.

Solution

Section A

1. (a) Corrosion

Explanation: The copper articles turn green when kept for long due to corrosion in which metal is eaten up gradually by the action of air, moisture or a chemical (such as an acid) on their surface.

2.

(c) Displacement reaction

Explanation: Reactions in which atoms or ions move from one compound to others to form a new compound are known as Displacement reactions.

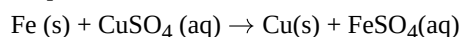

Fe being more reactive is able to displace Cu from CuSO₄ solution.

3.

(b) A, B, C and D

Explanation: All the above salts contain water of crystallization and their chemical formulae are given below:

Gypsum - CaSO₄.2H₂O - (2 molecules of water of crystallization)

Epsom salt - MgSO₄.7H₂O - (7 molecules of water of crystallization)

Blue vitriol - CuSO₄.5H₂O - (5 molecules of water of crystallization)

Glauber's salt - Na₂SO₄.10H₂O - (10 molecules of water of crystallization)

4.

(c) Sodium ethoxide and hydrogen

Explanation: This reaction can be shown by the following equations:

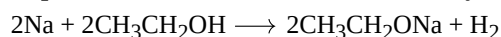

Therefore, the products formed are sodium ethoxide and hydrogen.

5.

(d) (i) and (iv)

Explanation: Aluminium has good thermal conductivity and high melting point. These properties are useful in the making of utensils. The commonly used metals in making utensils are copper, steel (an alloy of iron) and aluminium.

Copper and aluminium are the most preferred due to their conduction of heat.

6.

(d) Magnesium is below calcium but above aluminium

Explanation: Magnesium is below calcium but above aluminium

7.

(c) 7 covalent bonds

Explanation: Ethane - with the molecular formula C₂H₆ - has 7 covalent bonds. 1 covalent bond (C - C) exists between the two carbon atoms. 3 C - H covalent bonds are formed by 3 hydrogen atoms with each carbon atom.

8.

(c) endosmosis rate will be more

Explanation: Endosmosis rate will be more.

9.

(b) two individuals of a species

Explanation: species is the lowest level of classification and shows the high level of similarities among the organisms. so two individuals of a species have the maximum common characteristics.

10. (a) Fallopian tubes

Explanation: The fertilization of ovum takes place in the ampulla of the fallopian tube.

11.

(d) DNA

Explanation: Heredity is the passing on of traits from parents to their offspring, either through asexual reproduction or sexual reproduction; the offspring cells or organisms acquire the genetic information of their parents.

Heritable traits are known to be passed from one generation to the next via DNA, a molecule that encodes genetic information.

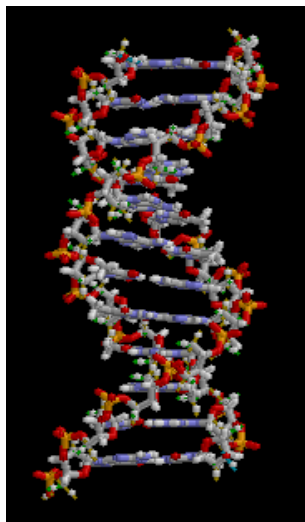

12.

(d) Carbon dioxide

Explanation: Because of respiration, Carbon dioxide gets accumulated in tissues. Hence, blood leaving the tissues becomes richer in Carbon dioxide.

13.

(d) Current flowing through the solenoid is saturated.

Explanation: Current flowing through the solenoid is saturated.

14.

(d) 0.06A

Explanation: Both bulb receive the same current because they are connected in series. They will have different voltages.

15.

(b) Transfer of energy from one trophic level to other is associated with energy loss

Explanation: The quantum of available energy in a food chain successively gets decreased at each trophic level as a result of energy loss. This limits the number of trophic levels in a food chain.

16.

(c) various interlinked food chains in an ecosystem

Explanation: A food chain is a series of plants/animals which are interrelated in the form of an organism being eaten as food by the other. The Food web is constituted by various interlinked and interdependent food chains in a community. It is also called a consumer-resource system. The ecosystem consists of living organisms and their abiotic environment. Thus, the correct answer is 'Various interlinked food chains in a community.'

17.

(c) A is true but R is false.

Explanation: Silver reacts with sulphur present in the air and forms a layer of silver sulphide, therefore, silver articles get tarnished. Thus assertion is true, but reason is false.

18.

(a) Both A and R are true and R is the correct explanation of A.

Explanation: DNA copying is necessary during reproduction because it leads to the transmission of characters from parents to offsprings and brings about variation.

19.

(a) Both A and R are true and R is the correct explanation of A.

Explanation: Here while carrying out an experiment if a compass needle is placed near a wire carrying current then due to the effect of magnetism which is produced due to electric current produced in the wire the needle gets deflected. Which shows that the magnetism and electricity are interlinked. So, both assertion and reason are true and reason is the correct explanation of assertion.

20.

(b) Both A and R are true but R is not the correct explanation of A.

Explanation: Plastics are non-biodegradable. They cannot be decomposed by the action of microbes. Recycling them can manage them effectively.

Section B

21. Methanol (CH₃OH) is oxidised to methanal (HCHO) in the liver.

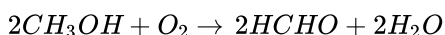

Methanal (HCHO) reacts rapidly with the components of body cells. It causes the protoplasm of the cells to coagulate. It also affects the optic nerve and causes blindness. Therefore, intake of small quantity of methanol can be lethal.

22. i. a. Testis - Anther
 b. Sperm - Pollen grains
 c. Ovary - Ovary
 d. Egg - Ovum

ii. Flowers are the main organs of sexual reproduction. They contain the reproductive organs.

23. a. The separation of oxygenated and deoxygenated blood in mammals and birds is necessary to produce more energy in order to maintain their body temperature at different climatic Conditions.
 b. Amphibians can withstand some amounts of blood that is both oxygenated and deoxygenated because they don't require a lot of energy. They alter their body temperature.

OR

| Respiration | Photosynthesis |
|---|--|
| 1) Being an exothermic process energy is released. | 1) Being an endothermic process, radiant energy of light is absorbed. |
| 2) It is a catabolic process in which food substrates are broken down. | 2) It is an anabolic process in which food substrates are synthesized. |
| 3) It takes place in all living cells. | 3) It is carried out only by the chlorophyll containing cells. |
| 4) CO ₂ is given out. | 4) O ₂ is released as a by product. |
| 5) Chemical energy is converted into ATP and some energy is lost as heat. | 5) Radiant energy of light is converted into chemical energy. |

24. The following figure shows a ray of light incident obliquely. Every medium has a critical angle. When angle of incidence is more than critical angle, the ray of light comes back in the same medium. This phenomenon is called total internal reflection.

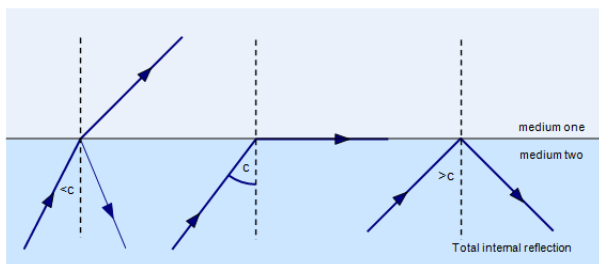

25. i. As uncle is supplying frogs from his village to laboratories so the number of frog population is decreasing. Frogs eat grasshoppers and mosquitoes. But as the number of frogs population is reduced so the population of grasshoppers and mosquitoes are increasing. So malaria is spread in the village by mosquitoes and grasshoppers are causing damage to the crops.
 ii. He must stop the supply of frogs to the laboratories as the reduced frog population is causing an imbalance in the food chain and proper ratio of frogs, grasshoppers and mosquitoes can not be maintained in the ecosystem.

OR

The maximum energy is available at T₁ trophic level and least at T₄. There is a progressive decline in the amount of energy available from producer to higher trophic levels, i.e. T₁>T₂>T₃>T₄ (energy). This is because at each trophic level, a large portion of energy is utilised for the maintenance of organisms at that trophic level and some are lost as heat and only about 10 percent is available to next trophic level and stored as biomass.

26. i. Different colours of light bend through different angles with respect to the incident ray as they travel with different speeds while passing through a prism, this phenomenon is known as dispersion of light.

- ii. X = violet, this colour has minimum wavelength thus suffers maximum deviation, Y = red, as it has maximum wavelength and thus least deviated.

Section C

27. (i) As the metal 'M' forms oxide M_2O_3 it is trivalent. Out of the metals listed, only *Fe* and *Al* are trivalent.
 (ii) M_2O_3 is not affected by water, so 'M' can be out of *Fe* or *Al*.
 (iii) *Fe* and *Al* both corrode easily.
 (iv) Out of *Al* and *Fe*, only *Fe* can form divalent chloride, so the element 'M' is *Fe*.
28. i. Formation of magnesium chloride - magnesium is a metal and chlorine is a non-metal. The magnesium atom loses 2 electrons to attain a stable configuration which results in the formation of magnesium cation Mg^{2+} .

Similarly, the chlorine atom gains an electron to complete its octet and results in the formation of chloride anion Cl^- .

When magnesium reacts with chlorine, two electrons lost by magnesium atoms are gained by two chlorine atoms. Mg^{2+} and Cl^- being oppositely charged, attract each other and are held by strong electrostatic forces of attraction to exist as $MgCl_2$.

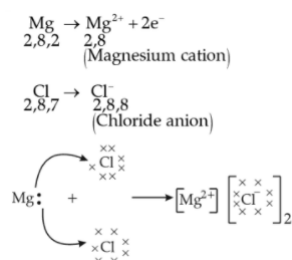

- ii. Due to the strong force of attraction between the metal with a positive charge and metal with a negative charge, ionic compounds are solid.
- iii. **Reaction with steam:** Metals like iron, zinc and aluminum react with steam to form corresponding hydroxide and hydrogen gas.

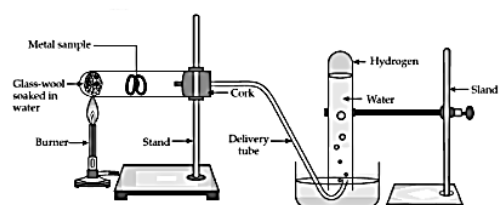

OR

- i. a. Ionic compounds have strong force of attraction between the oppositely charged ions (e.g., Na^+ and Cl^-), so they are solids. Covalent compounds have weak force of attraction between their molecules, so they are usually liquids or gases.
 b. Ionic compounds are soluble in water but covalent compounds are insoluble in water.
 c. Ionic compounds conduct electricity when dissolved in water or when melted because they contain ions (charged particles). But, covalent compounds like glucose do not conduct electricity because they do not contain ions.
- ii. a. The metal M which is in the middle of the reactivity series (such as iron, zinc, lead, copper, etc.) is moderately reactive. So, for obtaining such metals from their compounds, their sulphides and carbonates (in which they are present in nature) are first converted into their oxides by the process of roasting and calcination respectively. For example,



Zinc Sulphide
(Sulphide ore)

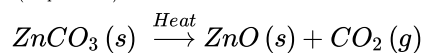

Zinc Carbonate
(Carbonate ore)

The metal oxide (MO) are then reduced to the corresponding metals by using suitable reducing agents such as carbon. For example, zinc metal from its oxide is obtained as follow:

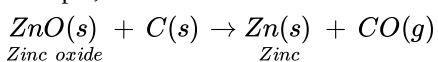

Zinc oxide

Zinc

- b. The metal N which is high up in the reactivity series (such as sodium, magnesium, calcium, aluminium, etc.), is very reactive and cannot be obtained from its compound by heating with carbon.
 Therefore, such metals are obtained by electrolytic reduction of their molten salt. For example, sodium is obtained by the

electrolysis of molten sodium chloride ($NaCl$).

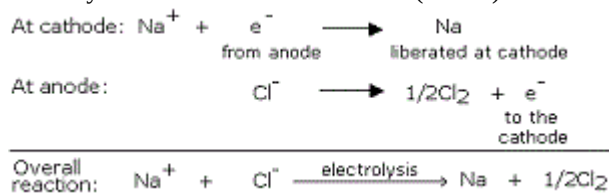

29. The deoxygenated blood is collected from the body tissues through the veins which further combine to form vena cava. This vena cava pours deoxygenated blood collected from the body tissues into the right auricle of the heart. From the right auricle, it goes to the right ventricle and from here the blood is pumped into the pulmonary artery which takes the deoxygenated blood from the heart to the lungs. In the alveoli of the lungs, the blood is oxygenated. This oxygenated blood is pumped into the pulmonary veins which pour the blood into the left auricle. From here the oxygenated blood is poured into the left ventricle. The left ventricle pushes the blood into the aorta which pumps the oxygenated blood into the body tissues and supplies oxygen through the tissues for various body functions.

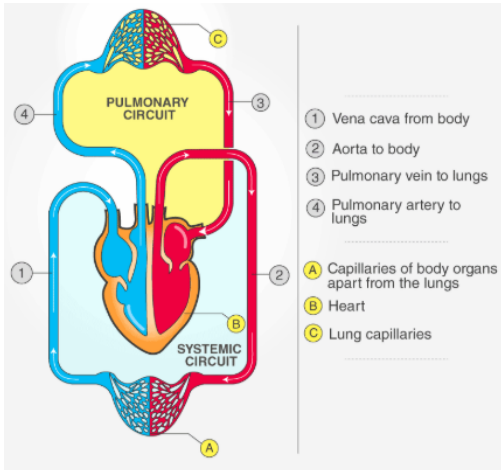
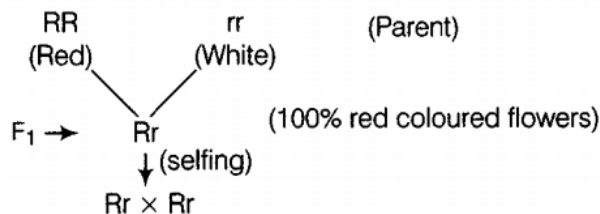

Figure: The double circulation of blood

30. When two plants, A with white flowers and B with red flowers were crossed, In F_1 generation all the plants have red coloured flowers and in F_2 generation the ratio of red : white is 3 : 1. The dominant trait is red colour in flowers. The recessive trait is white colour in flowers.



| Gametes | R | r |
|---------|---------|---------|
| R | RR(red) | Rr(red) |
| r | Rr(red) | rr(red) |

31. The virtual image formed by a concave mirror is always magnified whereas the virtual image formed by a convex mirror is diminished.

32. $1\text{ kWh} = 1000 \text{ watt} \times 3600 \text{ seconds}$

$$= 3.6 \times 10^6 \text{ wattsecond}$$

$$= 3.6 \times 10^6 \text{ joule (J)}$$

The SI unit of energy is joules (J).

33. i. Zero, current flows due to potential difference and not due to potentials.

ii. Energy consumed (in kWh) = power (in kW) \times time (h) = $2.2 \text{ kW} \times 3\text{h} = 6.6 \text{ kWh}$

$$\text{Power} = 2.2 \text{ kW} = 2.2 \times 1,000 \text{ W} = 2,200 \text{ W}$$

$$\text{But Power} = \text{Voltage} \times \text{Current}$$

$$2,200 = 220 \times I$$

$$I = \frac{2200}{220} = 10 \text{ A}$$

Section D

34. i. Soaps are molecules that have two ends with differing properties, one is hydrophilic (interacts with water), while the other end is hydrophobic (interacts with hydrocarbons). When soap is at the surface of water, the hydrophobic 'tail' of soap will not be soluble in water and the soap will align along the surface of water with the ionic end in water and the hydrocarbon 'tail' protruding out of water. Inside water, these molecules keep the hydrocarbon portion out of the water. Thus, clusters of molecules in which the hydrophobic tails are in the interior of the cluster and the ionic ends are on the surface of the cluster. This formation is called a micelle. Soap in the form of a micelle is able to clean, since the oily dirt will be collected in the centre of the micelle. The micelles stay in solution as a colloid and will not come together because of ion-ion repulsion. Thus, the dirt suspended in the micelles is also easily rinsed away. The soap micelles are large enough to scatter light.

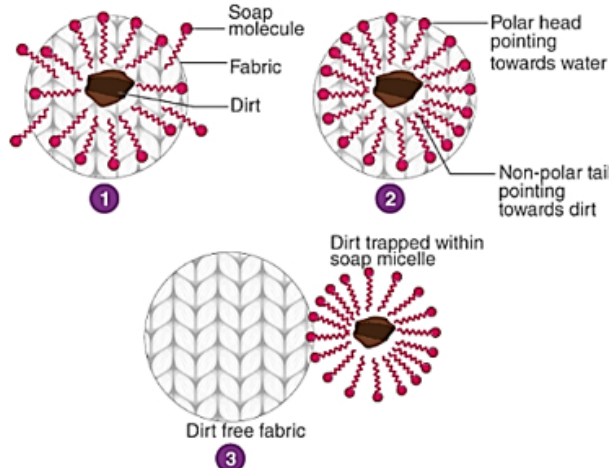

- ii. Detergents are sodium salts of sulphonic acids or ammonium salts with chlorides or bromide ions etc. Detergents have long hydrocarbon chains. The charged ends of these compounds do not form insoluble precipitates with the calcium and magnesium ions in hard water but soap reacts with calcium and magnesium ions present in the hard water to form insoluble substance called scum. Thus, detergents are better cleansing agents than soaps, they remain effective even in hard water.

OR

a. Isomers are those compounds which have the same molecular formula but different structural formula

- b.
 - Propanal- $\text{CH}_3\text{CH}_2\text{CHO}$
 - Propanone- CH_3COCH_3

Above are the name of these compounds and their structural formula.

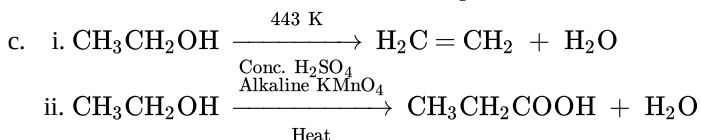

35. Binary fission in Amoeba. It is normal method of reproduction in Amoeba. It occurs under favourable conditions. The animal grows until it attains the maximum size and then divides by binary fission in every three or four days. The fission is completed in 15 to 20 minutes.

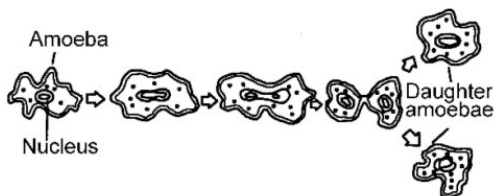

Multiple fission in Amoeba

Multiple fission inside the cyst has been described but not established. It has been suggested that sometimes inside the cyst, the nucleus divides and surrounds itself with cytoplasm to form several small amoebulae. At the return of favourable conditions or on finding a favourable substrate, the cyst absorbs water and its walls burst. The amoebulae escape and soon each one grows into new amoeba.

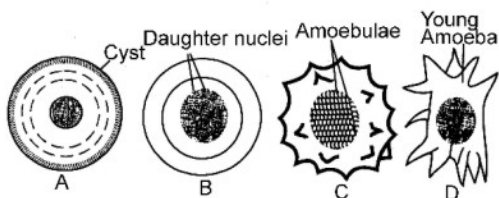

OR

The directional movement of a plant part/plant in response to light is called phototropism. The shoot responds by bending towards light while roots respond by bending away from the light. We know that the plant stem responds to light and bends towards it due to the action of auxin hormone. When sunlight comes from above, then the auxin hormone present at the tip of the stem spreads uniformly down the stem. Due to the equal presence of auxin, both the sides of the stem grow straight and with same rapidity. This is because auxin hormone moves away from the light.

Thus, more auxin hormone is present in the left side of stem as compared to the right. The left side of stem, grows faster than its right side and therefore, the stem bends towards the right side (direction of light).

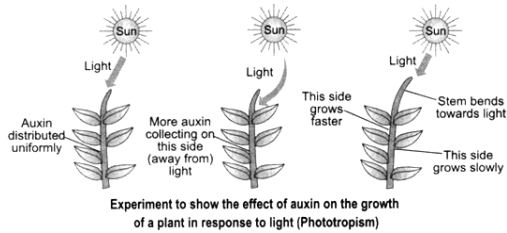

The effect of auxin on the growth of a root is exactly opposite to that on a stem. Auxin hormone increases the rate of growth in stem but it decreases the rate of growth in a root. The side of root away from light will have all the auxin concentrated in it. Due to this, the side of root which is away from light will grow slower than the other side and make the root bends away from light.

36. Given: Height of object (h_o) = 4 cm

Object distance (u) = -25 cm (-ve as it is in front of mirror)

Focal length (f) = -15 cm

i. Applying mirror formula and substituting the values,

$$\frac{1}{v} + \frac{1}{u} = \frac{1}{f}$$

$$\frac{1}{v} = \frac{1}{-15} - \frac{1}{-25}$$

$$\frac{1}{v} = \frac{-5+3}{75}$$

$$v = \frac{-75}{2} = -37.5 \text{ cm}$$

The negative sign indicates that the image is in front of the mirror.

Therefore, the screen must be placed in front of the mirror at a distance of 37.5 cm.

ii. Applying the magnification formula and substituting the values,

$$m = \frac{-v}{u} = \frac{h_i}{h_o}$$

$$\frac{-\left(\frac{-75}{2}\right)}{-25} = \frac{h_i}{4}$$

$$h_i = \frac{-75}{2 \times 25} \times 4$$

$$h_i = -6 \text{ cm}$$

The image will be 6cm high and it will be inverted.

iii. The ray diagram showing the formation of image in this case is,

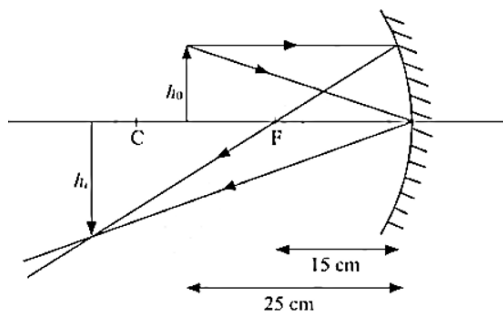

OR

When a convex lens is covered half with black paper as shown in diagram, then image of full object will formed, but it will be of less intensity and brightness.

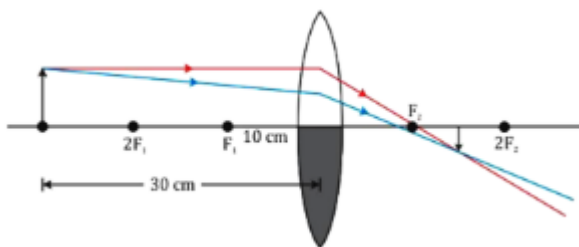

As $h_0 = 4 \text{ cm}$, $f = 20 \text{ cm}$ and $u = -15 \text{ cm}$

By lens formula,

$$\frac{1}{f} = \frac{1}{v} - \frac{1}{u}$$

$$\Rightarrow \frac{1}{v} = \frac{1}{f} + \frac{1}{u} = \frac{1}{20} + \frac{1}{(-15)} = \frac{15-20}{300} = \frac{-5}{300}$$

$$\therefore v = -60 \text{ cm}$$

As, magnification,

$$m = \frac{h_i}{h_0} = \frac{v}{u}$$

$$\Rightarrow h_i = h_0 \times \frac{v}{u} = 4 \times \frac{-60}{-15} = 16 \text{ cm}$$

Image formed is virtual, erect and magnified.

Section E

37. Read the text carefully and answer the questions:

Copper sulphate crystal contains water of crystallisation when the crystal is heated the water is removed and salt turns white. The crystal can be moistened again with water. The water of crystallisation is the fixed number of water molecules present in 1 formula unit of copper sulphate. On heating gypsum at 373K, it loses water molecules and became calcium sulphate hemihydrate.

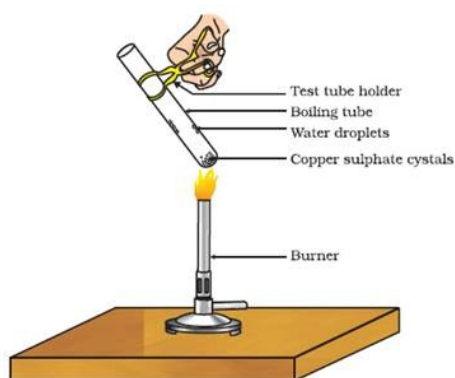

- (i) If the crystal is moistened with water, then the blue colour of the crystal reappears.
- (ii) The commercial name of calcium sulphate hemihydrate is Plaster of Paris.

OR

Five water molecules are present in one formula unit of copper sulphate.

38. Read the text carefully and answer the questions:

Environmental triggers such as light, or gravity will change the directions that plant parts grow in. These directional, or tropic, movements can be either towards the stimulus or away from it. So, in two different kinds of phototropic movement, shoots respond by bending towards light while roots respond by bending away from it. How does this help the plant? Plants show tropism in response to other stimuli as well. The roots of a plant always grow downwards while the shoots usually grow upwards and away from the earth. This upward and downward growth of shoots and roots, respectively, in response to the pull of earth or gravity, is, obviously, geotropism. If 'hydro' means water and 'chemo' refers to chemicals, what would 'hydrotropism' and 'chemotropism' mean? Can we think of examples of these kinds of directional growth movements? One example of chemotropism is the growth of pollen tubes towards ovules, about which we will learn more when we examine the reproductive

processes of living organisms.

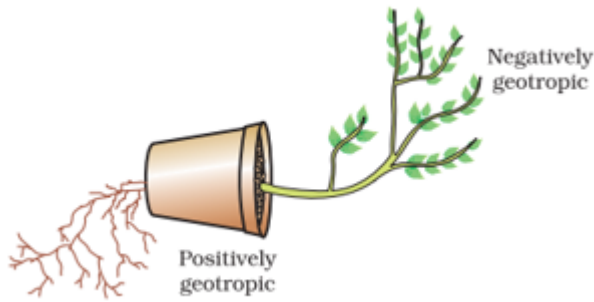

- (i) In plants, negative phototropism occurs in roots.
- (ii) Phototropism in shoots is attributed due to auxin in plants.
- (iii) Tendrils exhibit/ twining of tendrils show thigmotropism movement.

OR

Positive phototropic movement.

39. Read the text carefully and answer the questions:

A student was asked to perform an experiment to study the force on a current carrying conductor in a magnetic field. He took a small aluminum rod AB, a strong horse shoe magnet, some connecting wires, a battery and a switch and connected them as shown. He observed that on passing current, the rod gets displaced. On reversing the direction of current, the direction of displacement also gets reversed. On the basis of your understanding of this phenomenon, answer the following questions :

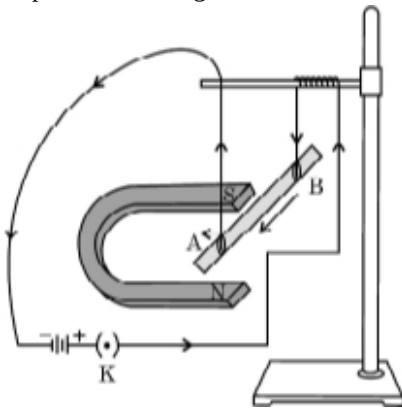

- (i) The displacement of the conductor is maximum when the direction of the current is at right angles to the direction of the magnetic field.
- (ii) The rule that determines the direction of the force on the conductor AB is Fleming's left-hand rule.
According to Fleming's left-hand rule, stretch the thumb, forefinger and middle finger of your left hand such that they are mutually perpendicular.
If the first finger points in the direction of the magnetic field and the second finger in the direction of current, then the thumb will point in the direction of motion or force.
- (iii) i. According to Fleming's left-hand rule, the rod will get displaced upwards.
ii. Devices that use current-carrying conductors and magnetic fields are electric motors, electric generators, loudspeakers, microphones, etc.

OR

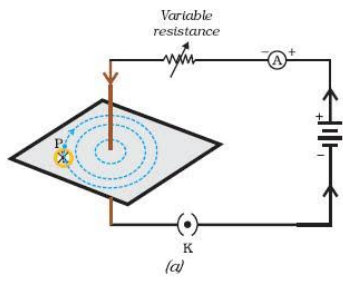

(b)